

# PERFORMANCE DATA

FINISHER (TIER 3)

BF 300 C



Greatest durability



Shorter set-up times



Exemplary efficiency

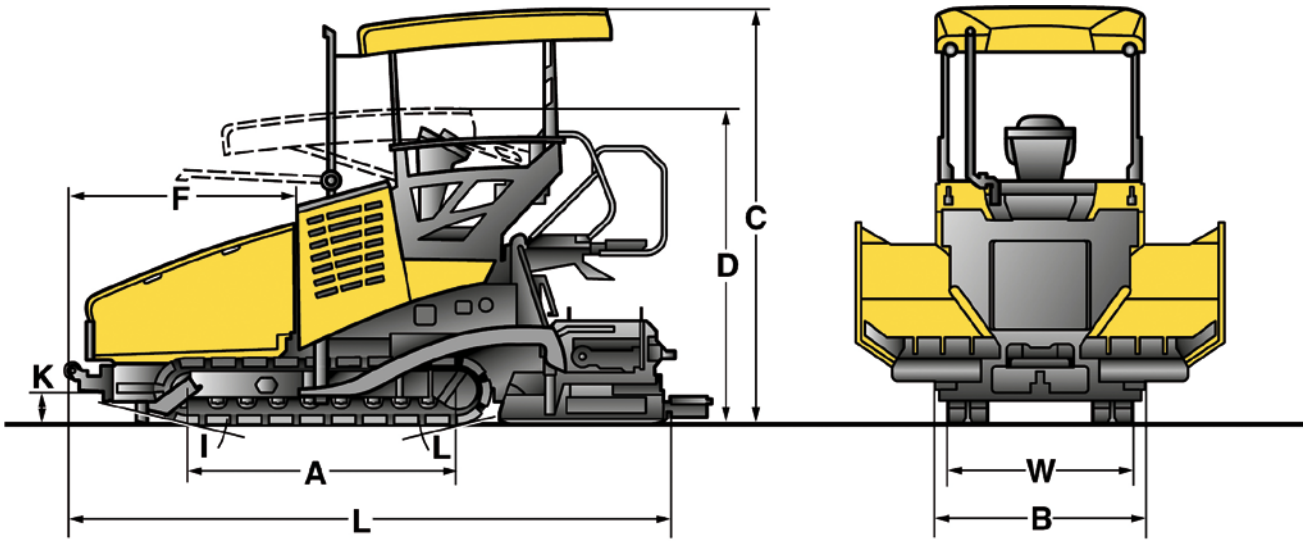

### Dimensions in mm

	A	B	H	H <sub>2</sub>	K	L	W
BF 300 C	2200	1740	3350	2600	170	4950	1700

### Shipping dimensions in m<sup>3</sup>

BF 300 C, S 340-2 EV	22,394
BF 300 C, S 340-2 ETV	22,394



Optional weather protection – for maximum convenience.

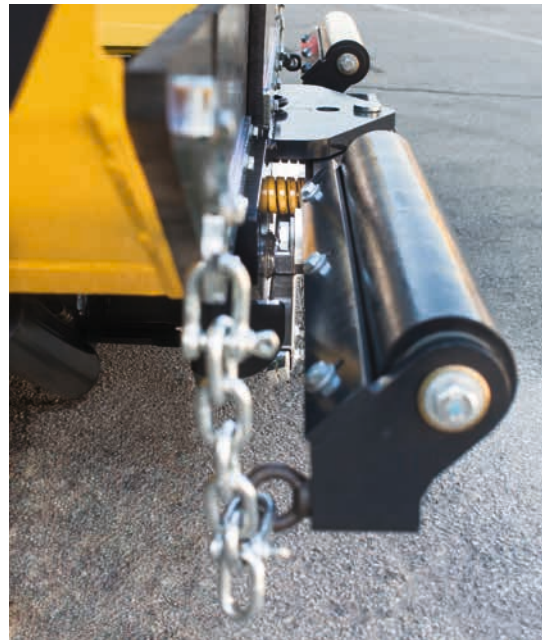

Impact-free docking – dampened bumper.



Save up to 17 % fuel – demand-driven hydraulics – with BOMAG ECOMODE.



Heats up nearly 60 % quicker – unique MAGMALIFE heating system.

**Technical Data****Weights**

Operating weight CECE ..... kg

**Dimensions**

Transport length ..... mm

Transport width ..... mm

Transport height ..... mm

**Travel characteristics**

Travel speed (1) ..... km/h

Working speed (1) ..... m/min

**Drive**

Engine manufacturer .....

Type .....

Emission stage .....

Cooling .....

Number of cylinders.....

Rated power ISO 3046..... kW / Hp

Rated speed..... min<sup>-1</sup>**Crawler assembly**

Crawler track.....

-Axle base ..... mm

-Width..... mm

**Hopper**Capacity ..... m<sup>3</sup>

Width (wings open)..... mm

Width (wings closed)..... mm

Length ..... mm

Filling height (middle) ..... mm

**Scraper belt / auger**

Number.....

Width ..... mm

Speed ..... m/min

Individual control.....

Reversing operation.....

**Conveyor auger**

-&gt;Number.....

-&gt;Auger diameter ..... mm

-&gt;Rated speed ..... 1/min

-&gt;Reversing operation.....

**Screed**

Screed type.....

Basic width retracted ..... mm

Basic width extended..... mm

Max. working width..... mm

Min. width with reduction skids ..... mm

Mat. thickness..... mm

Smoothing plate depth..... mm

Smoothing plate thickness..... mm

Heating .....

Crown ..... %

Tamp frequency..... Hz

Vibration frequency ..... Hz

Basic weight..... kg

**Filling capacities**

Fuel..... l

Hydraulic oil..... l

**Operating/control elements**

Number of drier's seats.....

Side View.....

LCS System .....

**BOMAG****BF 300 C, S 340-2 EV**

9400

4950

1740

2600

0-4,9

0-26

Kubota

V3307 T

Stage III a / TIER 3

Water

4

54,6 / 72,8

2250

2200

260

4,8

3075

1740

1660

540

2

220

30

Standard

Standard

2

280

100

Standard

S 340-2 EV

1700

3400

5000

750

250

330

12

Electric

-3 ... +4,5

20-50

20-50

1500

100

80

1

Standard

Standard

**BOMAG****BF 300 C, S 340-2 ETV**

9550

4950

1740

2600

0-4,9

0-26

Kubota

V3307 T

Stage III a / TIER 3

Water

4

54,6 / 72,8

2250

2200

260

4,8

3075

1740

1660

540

2

220

30

Standard

Standard

2

280

100

Standard

S 340-2 ETV

1700

3400

5000

750

250

330

12

Electric

-3 ... +4,5

0-30

20-50

1720

100

80

1

Standard

Standard

### Standard equipment

- ECOMODE
- Lateral seat ad platform adjustment, Side View System (pat.)
- GRP-roof, hydr. tiltable, 4-fold roof lighting
- L.C.S. Screed relief system
- Individually controlled hopper wings
- Reversible and individually controlled scraper belts
- Reversible and individually controlled augers
- Continuous tamper and vibration adjustment
- Fully automatic screed heating
- Cast heating elements
- BOMAG central electrics, service and fault code display
- Hydr. pre-tensioning of crawler tracks with overload protection
- Remote control of material flow sensors from the lateral screed control panels
- Mechanical crown adjustment
- Electro-mechanical sensors for scraper belts
- Ultrasound sensors for augers
- Central lubrication for screed and auger

### Optional equipment

- Screed extension 30 cm, 50 cm (3.4 m to 5.0 m)
- Cleaning kit
- Hydraulic auger lift
- Ultrasound sensors for scraper belts
- Hydraulic crown adjustment
- Optional paint finish
- Ultrasound or electro-mechanical levelling systems
- Cross-slope levelling system
- Electric side plate heating for screed S340E
- Automatic central lubrication system for screed and auger
- Spring-mounted pushing roller yoke

